

23.6" IP PVM PoE Power and Data Monitor



FEATURES

- 23.6-Inch Screen Size / 1920 x 1080 FHD Resolution
- Interface: CVBS Camera Out/ HDMI In/ VGA In/ RJ45 Out/ SD Slot / USB
- 1080p IP Camera / Auto Switch Sensor
- On Screen Warning Message On/Off
- Motion Sensor for Auto Switch
- PoE Standard IEEE802.3bt, 60W Max PoE Power & Data
- 24/7 Operation Design
- NDAA Compliant / 3-Year Warranty

DIMENSIONS

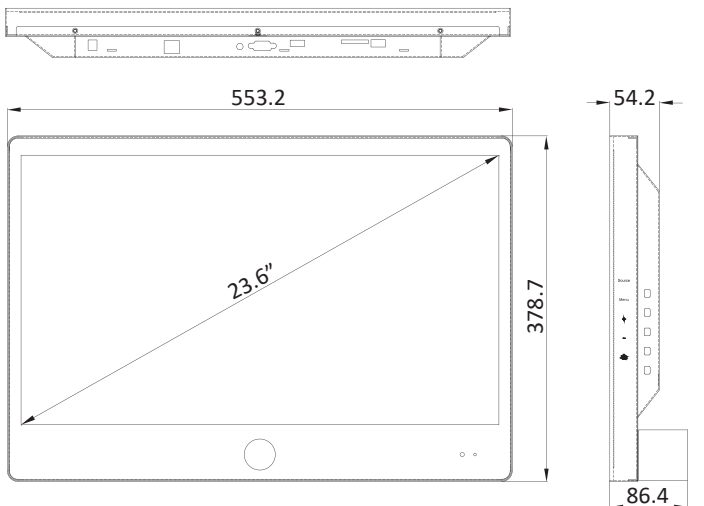

PVM24ZD-OC3-4

SPECIFICATIONS	
Size	23.6 In
Resolution	1920 x 1080
Aspect Ratio	16 : 9
Response Time	5ms
Viewing Angle	178° / 178°
Brightness	300cd/m ²
Contrast Ratio	1000 : 1
Color	16.7M
Backlight	LED
Interface	CVBS Camera Out x1, HDMI In x1, VGA In x1 SD Slot x1, RJ45 Out x1, USB x1
Camera Sensor	1/2.8" STARVIS Sony Sensor
Camera Resolution	1920x1080@25fps
WDR	120dB
Face/Mask Detection	Yes
Min. Illumination	0.1 Lux (Color), 0.01Lux (B/W)
Compression	H-264, H.265
Compliance	Onvif Profile S/Q/G/T
Lens	3.3-12mm Vari-focal IR Corrected
Recording	Local Micro SD, Remote FTP
Network Protocol	Onvif , IPv4,802.1x,HTTP, HTTPS, TCP/IP, UDP/IP, RTSP, DHCP, NTP, RTCP/RTP, PPPoE, SMTP, DNS, UPnP, FTP, ARP, SNMP Smart tracking box
SD Card Resolution	1920X1080@30fps
Max. Support Volume	64GB NTFS/FAT32
Max. Stream	15Mbit/s
Supporting Format	AVI, MOV, MP4, 3GP, MPG, VOB, DAT, WMV, ASF, JPEG, BMP, MP3, WMA
Cabinet Matrial/Color	Metal/Black
Power Consumption	28W
Electrical Ratings	DC24V/1.45A (AC 110V ~ 240V, 50/60Hz)
PoE Requirement	PoE Standard IEEE802.3bt / 60W
Operating Temp.	32° F ~ 122° F (0° C ~ 50° C)
Storage Temp.	-4° F ~ 140° F (-20° C ~ 60° C)
Humidity	10% ~ 85%
Dimensions (In/mm)	21.77 x 14.90 x 2.13 / 553.2 x 378.7 x 54.2
Net Weight	21.6 lbs (9.8 kg)
Certification	NDAA / FCC / CE / RoHS
VESA™	100 x 100
Accessories	AC adapter, Remote control, User's manual

**Specifications may change without any notice

30398 Esperanza,
Rancho Santa Margarita, CA 92688

888-651-9688 / 949-586-3338

sales@gvision-usa.com
https://www.gvision-usa.com

