

P19 Series

SXGA 1280x1024 / Resistive Touchscreen Monitors

19"

Model Name:

- P19BC-AB-459G
- P19BH-AB-459G



// DESCRIPTIONS

Gvision's P19 series, compliant with TAA standards, represents a 19-inch industrial-grade desktop POS-type monitor tailored for professional environments. Equipped with a 5-wire resistive touchscreen, it is meticulously designed to withstand demanding conditions. With its robust construction and precise touchscreen technology, the P19 series stands out as an ideal solution for harsh operating environments requiring reliable performance.

Our distinctive desktop POS display monitor is available in two resolutions: WXGA 1366x768 with a 16:9 aspect ratio, or standard SXGA 1280x1024 with a 5:4 ratio.

// KEY FEATURES

- 19-Inch Screen Size
- 1280 x 1024 (P19BH) / 1366 x 768 (P19BC) Resolution
- Interface: DVI / VGA / USB / RS232 / Audio
- 5-Wire Resistive Touch Panel
- Advanced OSD for Picture Quality Adjustment
- USB and Serial Port for Touch Interface
- 24/7 365 Operation Commercial Grade Monitor
- TAA Compliant
- 3-Year Warranty



// SPECIFICATIONS

	P19BC-AB-459G	P19BH-AB-459G
DISPLAY		
Size	19 In	19 In
Resolution	WXGA 1366 x 768	SXGA 1280 x 1024
Display Area (mm)	409.8 (H) x 230.4 (V)	376.4 (H) x 301.1 (V)
Aspect Ratio	16 : 9	5 : 4
Viewing Angle	170° / 160°	170° / 160°
Response time	3.5ms	5ms
Brightness	250cd/m ²	350cd/m ²
Contrast Ratio	1000 : 1	1000 : 1
Color Depth	16.7M	16.7M
Backlight	LED	LED
INTERFACE		
Ports	DVI x1, VGA x1, Audio x1, USB x1, RS232 x1	DVI x1, VGA x1, Audio x1, USB x1, RS232 x1
TOUCH		
Type / Point	Resistive / 5-Wire	Resistive / 5-Wire
Interface	RS-232 or USB	RS-232 or USB
FEATURES		
Support OS	Windows / Linux	Windows / Linux
AUDIO		
Speakers	2 Speakers, 1W/Ch	2 Speakers, 1W/Ch
CABINET		
Color / Material	Black / Plastic	Black / Plastic
POWER		
Electrical Rating	DC 12V/5A (AC 100V ~ 240V, 50/60Hz)	DC 12V/4A (AC 100V ~ 240V, 50/60Hz)
TEMPERATURE		
Operating / Storage	32°F ~ 104°F (0°C ~ 40°C) / -4°F ~ 140°F (-20°C ~ 60°C)	
DIMENSIONS (WxHxD)		
Inch / Millimeter	17.3 x 12.7 x 7.2 / 440.2 x 324.3 x 183.4	17.2 x 16.4 x 7 / 436.8 x 417.5 x 180
WEIGHT		
Net Weight	9.4 lbs (4.3 kg)	17.6 lbs (8 kg)
VESA™		
Mount Size (mm)	100 x 100	100 x 100

// DIMENSIONS

P19BC

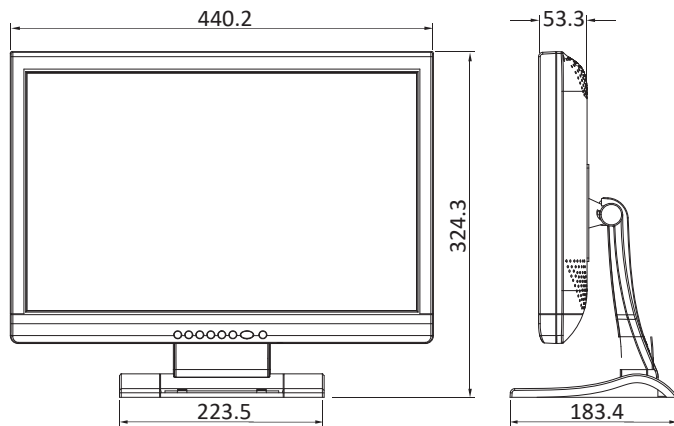

P19BH

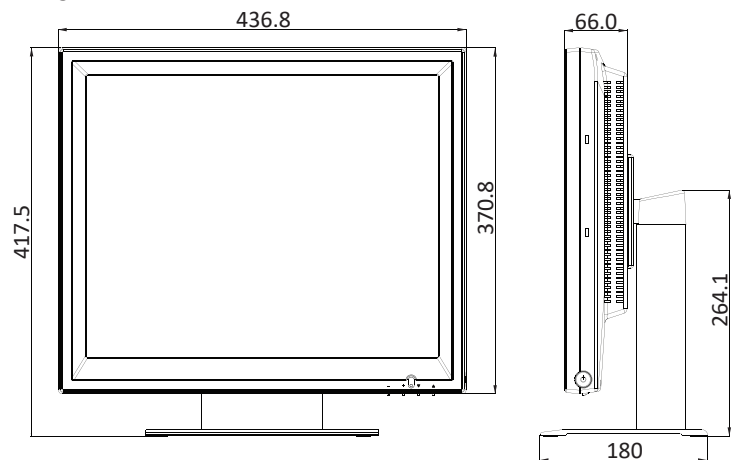

Unit: mm

Note: Panel and specifications subject to change without notice.