

19" Medical Grade Touchscreen Monitor



FEATURES

- 19-Inch Screen Size
- 1280 x 1024 Resolution
- Interface: VGA / DVI / USB Type-A / RS232
- 5-Wire Resistive 1-Point Touch
- UL60601 Certified
- Integrated Stereo Speakers / Designed for 24/7 Operation
- LED Backlight Unit Monitor
- TAA Compliant / 3-Year Warranty

DIMENSIONS

UNIT:MM

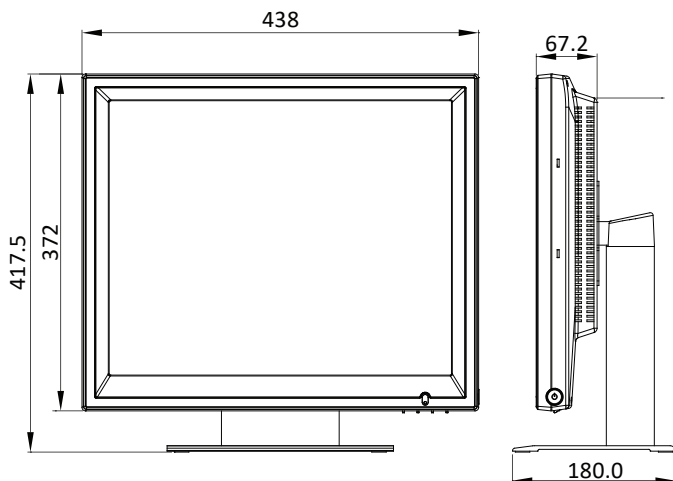

MA19BH SERIES

SPECIFICATIONS	
Size	19 In
Resolution	1280 x 1024
Display Area (mm)	376.4 (H) x 301.1 (V)
Aspect Ratio	5 : 4
Response Time	5ms
Viewing Angle	170° / 160°
Brightness	350cd/m ²
Contrast Ratio	1000 : 1
Color	16.7 M
Backlight	LED
Interface	DVI x1, VGA x1, USB Type-A x1, RS232 x1
Speaker	1W Per Channel
Touch Type	Resistive
Touch Point	5-Wire / 1-Point Touch Resistive
Touch Interface	RS-232 or USB A Type
Cabinet Material	Plastic Frame / Metal Housing
Cabinet Color	White
Power Consumption	< 20W
Electrical Rating	12V DC/5A (AC 100V~240V, 50/60Hz)
Operating Temp.	32° F ~ 104° F (0° C ~ 40° C)
Storage Temp.	-4° F ~ 140° F (-20° C ~ 60° C)
Humidity	10% ~ 80%
Dimensions (In/mm)	17.2 x 16.4 x 7 / 438.0 x 417.5 x 180.0
Net Weight	17.6 lbs (8.0 kg)
Certification	UL60601, FCC, RoHS / WEEE
VESA™	100 x 100

***Specifications may change without any notice*

ORDERING INFO

Model Name	Touch Screen
MA19BH-AB-1290	Elo Controller Board
MA19BH-AB-1690	eGalax

30398 Esperanza,
Rancho Santa Margarita, CA 92688

888-651-9688 / 949-586-3338

sales@gvision-usa.com
<https://www.gvision-usa.com>

